

Gigabit Serial Link Module RTM-T



RTM-T Specification

PCI-Express on cable x1 Port.

Scaleable system matches ACQ1xx data rate, one link per card for matching bandwidth

Multiple links means data farming at the host is modular. Easy to add additional hosts as the data rate increases.

PCIe data link is a NON TRANSPARENT bridge – host and target systems may be powered up independently. Simpler host side drive interface.

Fiber-optic data interface on SFP fiber.

D-TACQ offer an SFP HBA capable of streaming data over long distance.

Gigabit Ethernet port – 1000T with IEEE1588 capability.

Large FPGA with embedded microprocessor and DSP capability.

Applications

Continuous Streaming Data connects CPCI card to PCI-Express.

Isolated Systems using fiber optic connection.

Dynamic User Inline DSP [DRUID]

Description

RTM-T is a Rear Transition Module backwards compatible with ACQ196CPCI, ACQ132CPCI, ACQ164CPCI and AO32CPCI. RTM-T provides modern, fast gigabit serial communications links for the existing product line.

PCI Express x1 Data Link

Rear panel connector, connects the slot to a PC-host PCI-Express root complex via a suitable host bus adapter HBA. The port complies fully with PCISIG PCI-Express on Cable specification. The link comprises the standard Molex cable in lengths up to 15m. RTM-T includes a programmable transceiver with cable length compensation. Low cost HBA's are available from a number of vendors; the link has been tested with the commonly-available NI-MXI-Express card. This is available in single and two-port units. D-TACQ has operated this link continuously at rates in excess of 200MBytes/s.

Fiber Optic Data Link on SFP.

SFP module provides a universal interface to gigabit fiber communications. D-TACQ offers a matching HBA and device driver.

Gigabit Ethernet Port.

Simple, low cost connectivity using TCP/IP. Useful for control and low rate data streaming. The port features an IEEE1588-capable PHY to allow integration with network-based precision timing systems.

Large FPGA resource

High density but low-cost FPGA enables microprocessor supervisory and DSP functions. This platform enables DRUID, where users can configure inline DSP at low cost.

System on a Board Concept

RTM-T is capable of controlling AO32CPCI, making a low cost networked AWG in a slot.

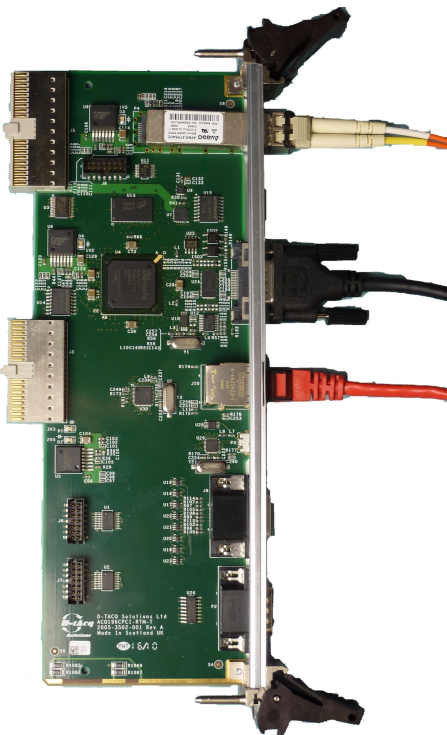

Part Number	Description
RTM-T	RTM with gigabit links, compatible with ACQ196CPCI, ACQ132CPCI, AO32CPCI.

Features

SFP Port		PCI-Express Port	
Rate	2.5 Gbit/sec,	Rate	200 Mbytes/sec, sustained
Protocol	Aurora	Distance	Up to 15 m copper cable
Transceiver	SFP, bi directional	Out of Band	Cable present, reset, wakeup.
		Trim	Cable driver with dynamic compensation for cable length

Gigabit Ethernet		DIO6	
Type	Copper, RJ45, 1000T	Signals	6, bi directional TTL.
Protocol	TCP/IP	Console	
PHY	IEEE 1588-2008 enabled	UART	RS232, up to 115200 baud.

FPGA		Memory	
Model	Xilinx Spartan S6LX45T	DDRAM	128MB, DDR3
Serial Ports	4 MGT Links, including PCIe 1x	FLASH	32+32 MB

Interfaces

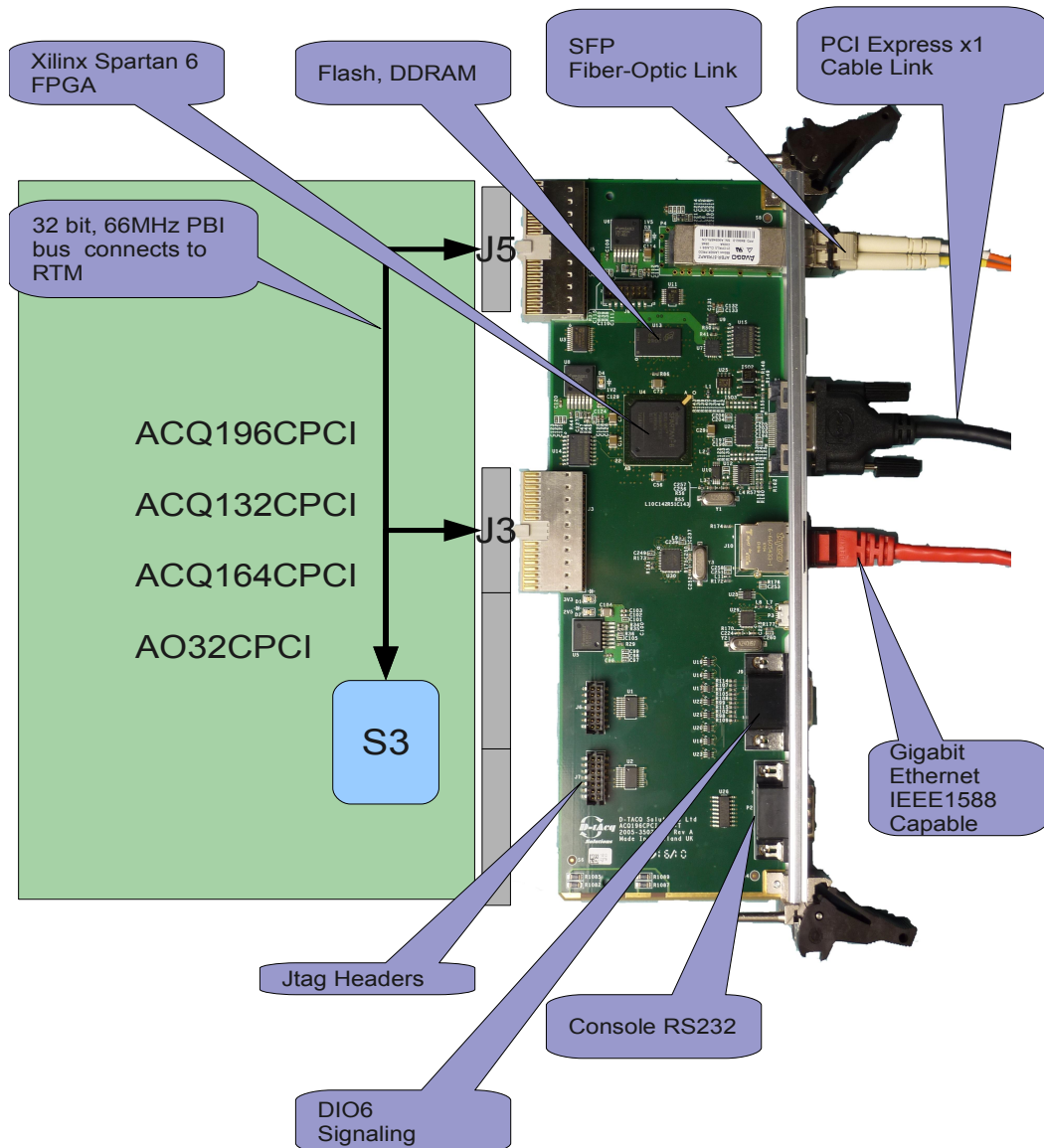

RTM-T Use-Cases

Use Case: ACQ196CPCI, Stream Data at 96ch x 500kSPS

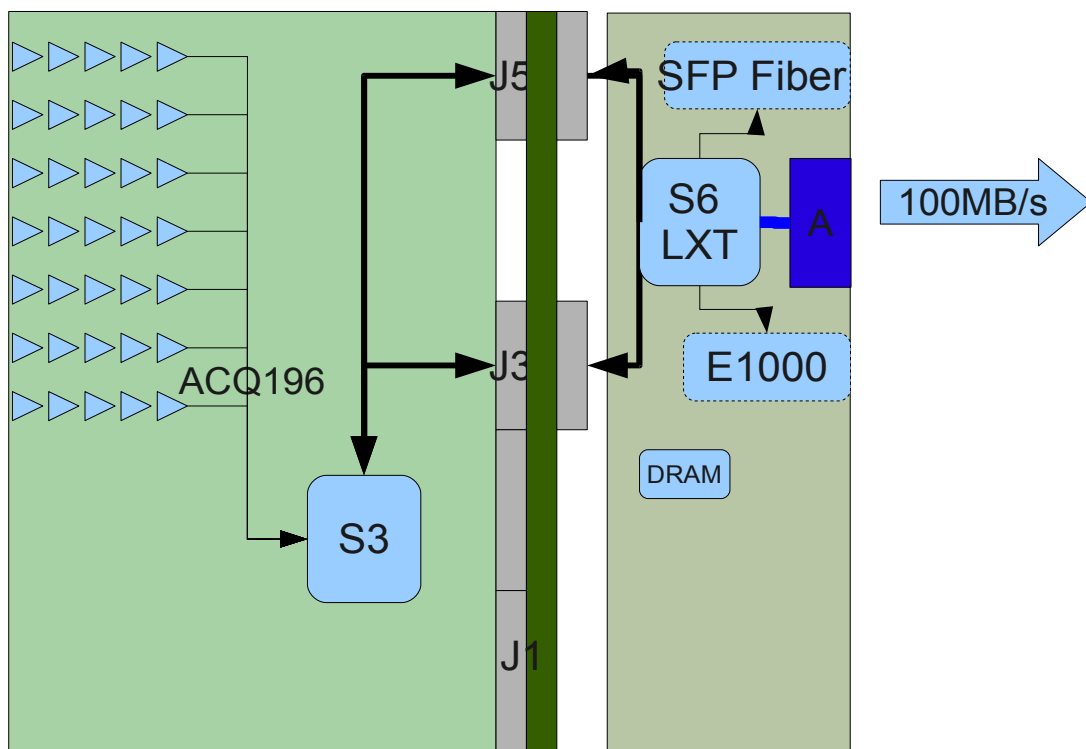

Use Case: ACQ132CPCI, Stream Data at 32ch x 3MSPS

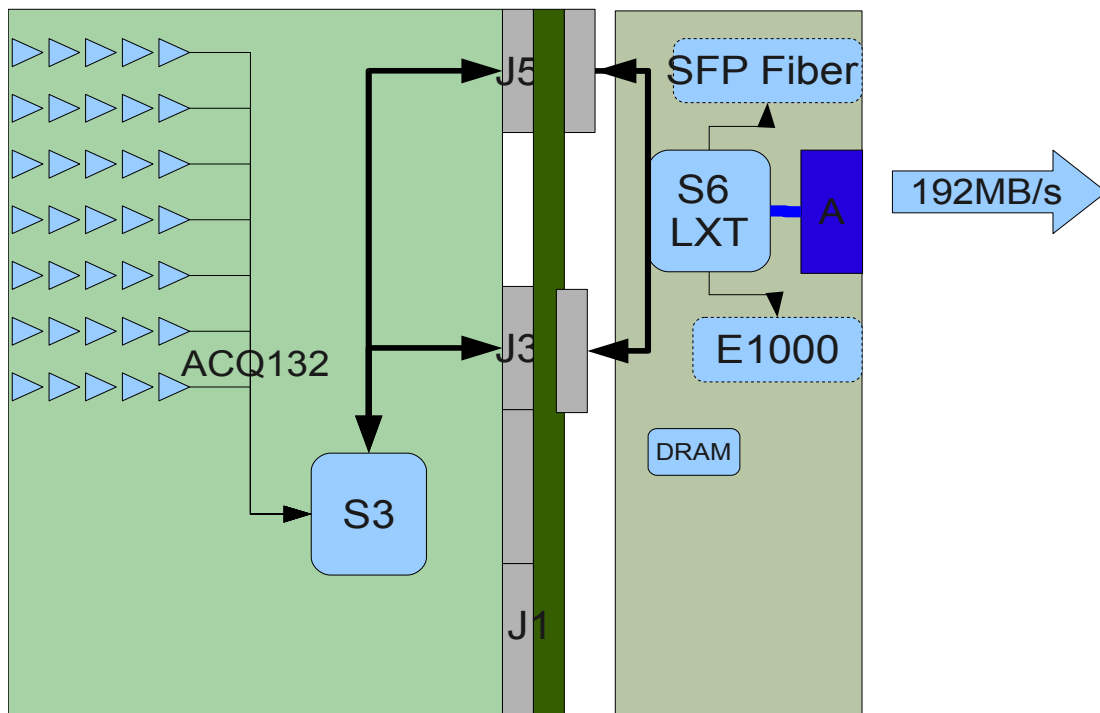

Use Case: AO32CPCI, Standalone AWG

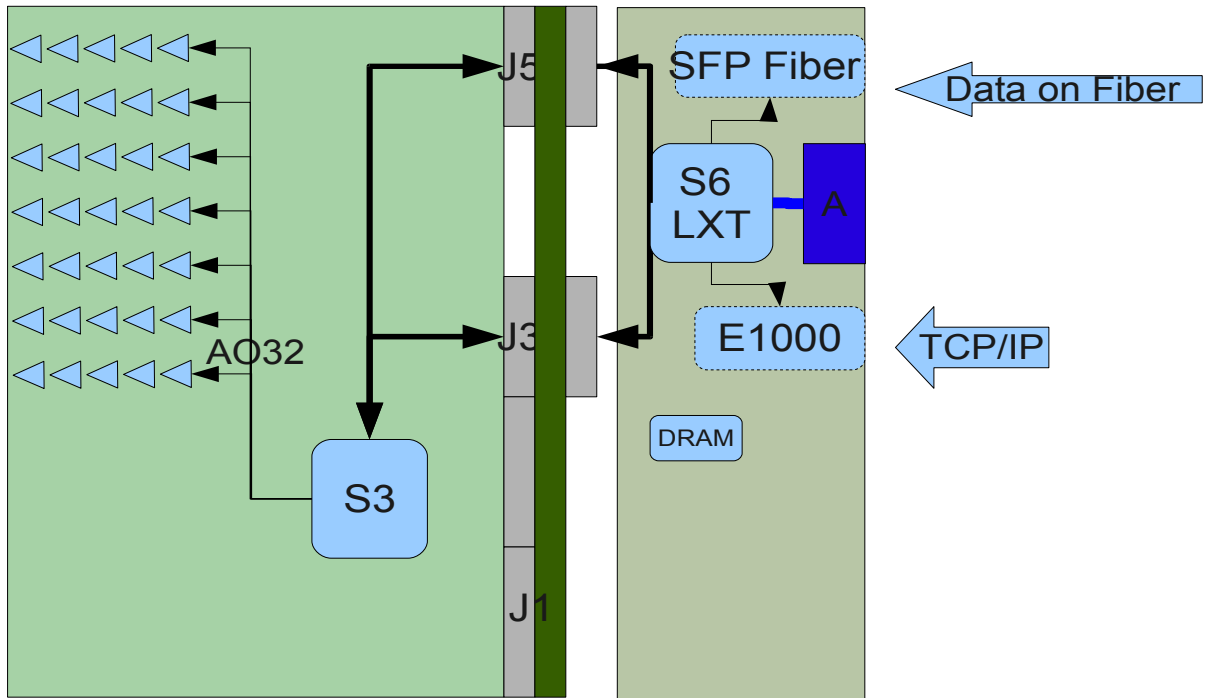

Example: 4 x96 channel streaming data system

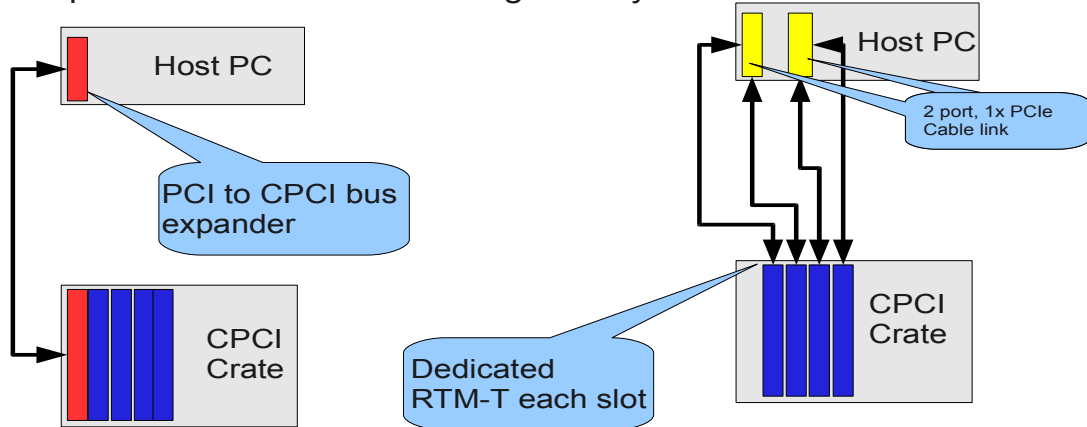

Old System: 4 x ACQ196 CPCI, bus expander
4 x 100 kSPS

New System: ACQ196CPCI+RTM-T
4 x 500 kSPS



D-TACQ Solutions Ltd.
James Watt Building, Scottish Enterprise Technology Park, East Kilbride, Scotland,
G75 0QD United Kingdom.
Tel: +44 1355-272511 Fax: +44 0870-0560474, Email: info@D-TACQ.co.uk
Website: - www.D-TACQ.com

All registered trademarks acknowledged..
Information on this datasheet is subject to change without notice. No liability is accepted for any
information contained in this data sheet