

Description

The PhotoniQ model MCPC618 is a complete, off-the-shelf, high speed, eight channel photon counting system for PMTs, silicon photomultipliers (SiPM) and APDs. Implemented as a stand-alone laboratory instrument with a PC interface, the MCPC618 is used for preamplification, discrimination, counting, and data acquisition (DAQ) of single photon events across eight independent counting channels. Its unique front end design permits direct connection to most PMTs without the need for an external preamplifier. Flexible intelligent triggering allows the unit to reliably acquire count data using one of several sophisticated triggering techniques. The MCPC618 is fully configurable through the PC via its USB 2.0 port using an included graphical user interface. Continuous high speed data transfers to the PC are also handled through this port. Additionally, a LabView™ generated DLL is provided for users who wish to write their own applications that interface directly to the unit.

Applications

- Fluorescence Spectroscopy
- Fluorescence Lifetime Measurement
- Chemiluminescence Detection
- Bioluminescence Detection
- Photon Correlation Spectroscopy
- DNA Sequencing
- Particle Sizing
- LIDAR
- Flow Cytometry
- Neutrino Detection
- Spatial Radiation Detection
- Confocal Microscopy
- Particle Physics



Features

- Includes eight independent counting channels with on-board preamps and discriminators
- Maximum count rate greater than 250 MHz per channel for a total of 2 billion counts per second
- Pulse pair resolution of less than 4 nsec
- Internal or external discriminator threshold control
- Flexible control of counting period parameters such as delay, width, or external boxcar
- Adjustable microGate provides additional level of gating at sub-nanosecond time resolution
- Synchronization of microGate to external excitation source
- Parallel, high speed hardware processor unit performs real-time data filtering and dark count subtraction
- Programmable data filtering function for real time detection of predefined energy patterns or spectrums
- Advanced triggering supports edge, internal, level, boxcar, pre-triggering and input threshold crossing modes
- Trigger stamping and time stamping with 100 nsec resolution
- USB 2.0 interface supports high data transfer rates
- Graphical User Interface (GUI) for menu driven data acquisition and configuration
- LabVIEW™ generated DLL for interface to custom applications

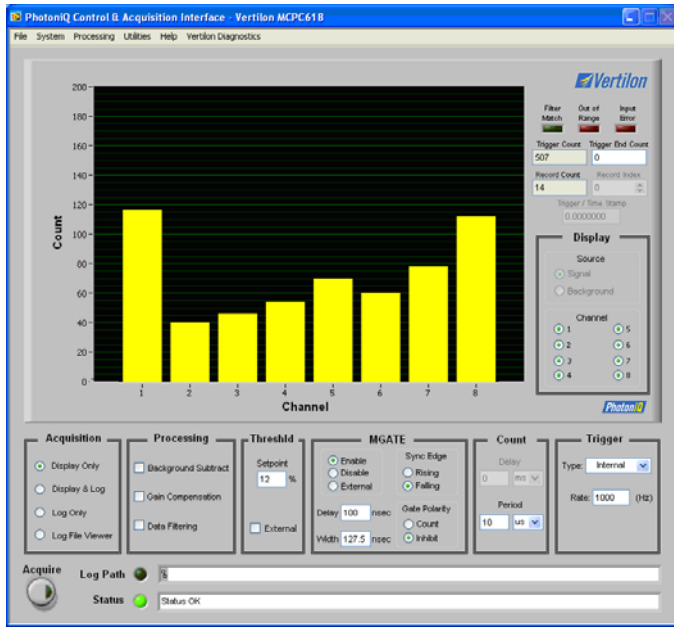

Software Features & Functions

- Graphical User Interface (GUI) for menu driven data acquisition, configuration, and status
- Real time display shows total count for count period across all channels for each trigger
- Integrated log file viewer permits on-screen viewing of logged count records
- Microgate width and delay controllable in GUI with 500 psec resolution
- Fully programmable count period minimizes dead time
- High speed trigger counter and record counter
- Acquisition can be programmed to acquire for a preset number of records
- Trigger stamping and record time stamping with 100 nsec resolution
- USB 2.0 interface supports high transfer rates
- Included Microsoft Windows DLL for interface to custom user applications

Included Accessories and Software

The MCPC618 is enclosed in a rugged, EMI-shielded, instrument case and is shipped with the following standard components and software:

- PhotoniQ Control and Acquisition Interface Software CD-ROM
- DC power supply (+5V, 2A) with power cord
- USB 2.0 cable

Recommended Sensor Interface Circuits

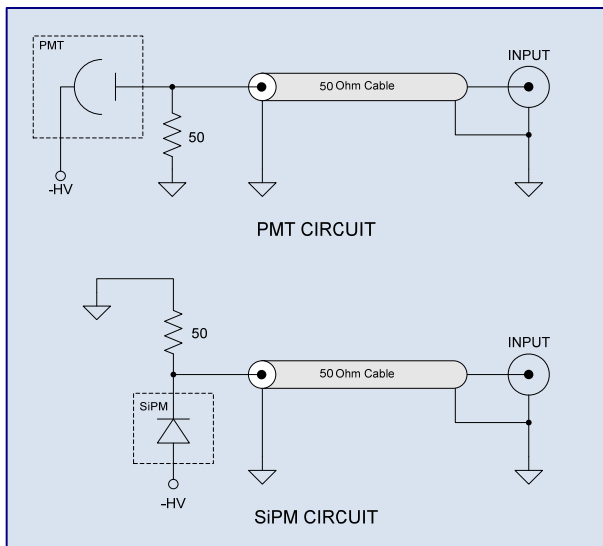

Specifications

Description	Specification
Number of Channels	8
Input Impedance	50 ohm
Input Preamplifier Gain	20 dB
Input Preamplifier Bandwidth	400 MHz
Pulse Pair Resolution (PPR)	4 nsec max.
Minimum Detectable Pulse Amplitude	8 mV
Maximum Count Rate per Channel	250 MHz
Count Period Range	100 nsec to 1 sec
Maximum Count per Count Period	32,767
Maximum Trigger Rate	400 KHz
Sustained Trigger Rate (8 Channels Enabled)	250 KHz
Power Consumption	5 Watts typ.
Width	9.843 in. (250 mm)
Height	3.346 in. (85 mm)
Length	10.236 in. (260 mm)

* See MCPC618 User Manual for details



Vertilon Corporation has made every attempt to ensure that the information in this document is accurate and complete. Vertilon assumes no liability for errors or for any incidental, consequential, indirect, or special damages including, without limitation, loss of use, loss or alteration of data, delays, lost profits or savings, arising from the use of this document or the product which it accompanies.

Vertilon reserves the right to change this product without prior notice. No responsibility is assumed by Vertilon for any infringements of patents or other rights of third parties which may result from its use. No license is granted by implication or otherwise under the patent and proprietary information rights of Vertilon Corporation.

© 2010 Vertilon Corporation, ALL RIGHTS RESERVED

PS2720.1.0 Aug 2010

Vertilon Corporation, 66 Tadmuck Road, Westford, MA 01886 / Tel: (978) 692-7070 / Fax: (978) 692-7010 / www.vertilon.com